

## CUSTOM PRECAST PITS

### APPLICATIONS

- Council and private subdivisions
- Projects for various bodies such as -
  - Water Authorities
  - Road Authorities
  - Rail Authorities
  - Port Authorities
  - Airport Authorities
  - Mining Industry
  - Power Authorities
  - Local Government bodies
  - Contractors, and others.
- Situations involving large diameter pipes
- Where standard precast pits are not suitable

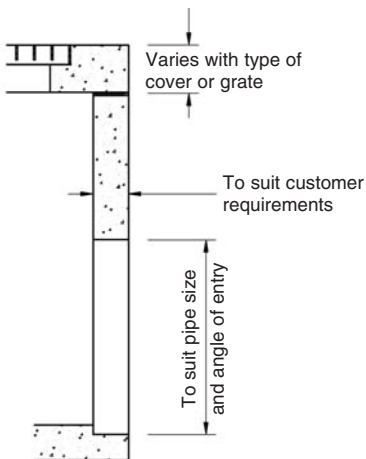
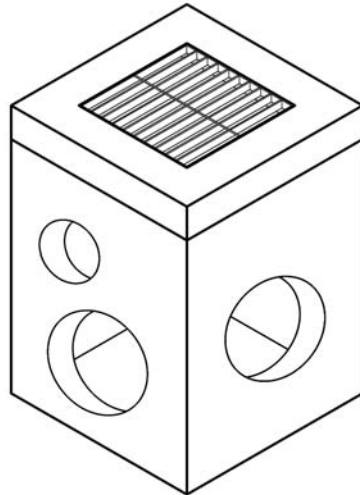

### NOTES

- Walls - 100, 125, 150, 200, 250, 300mm or as required
- Step-irons loose or installed as required
- Round or elliptical holes to suit pipe sizes and angle of pipe entry
- Internal pit height as required
- Wide range of covers and grates to BCP or customer design
- Pits appropriately labelled for easy identification
- Delivered on crane trucks with mobile phones for better customer service. (Some larger pits may require crane hire to unload and install)

## Precast Solutions

Beresford Concrete Products Pty Limited ABN 66 002 104 323 trading as

**BCP Precast PO Box 4197 Lake Haven NSW 2263**

Phone: 1800 804 134 Fax: 1800 199 916 Email: [sales@bcp.com.au](mailto:sales@bcp.com.au) Web: [www.bcp.com.au](http://www.bcp.com.au)

## TYPICAL CUSTOM PRECAST PITS

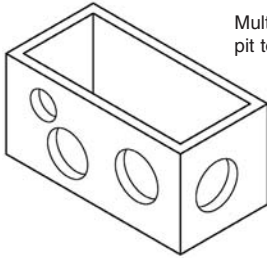

Multiple and various size holes in the pit to suit customer requirements.

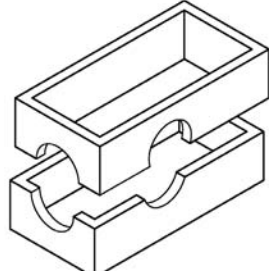

Split along pipe centerlines to facilitate installation where large pipe sizes are involved.

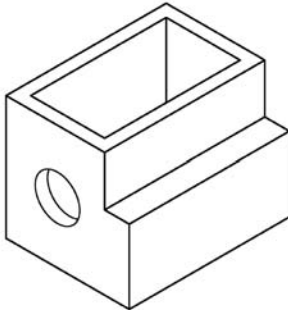

Haunch Pits

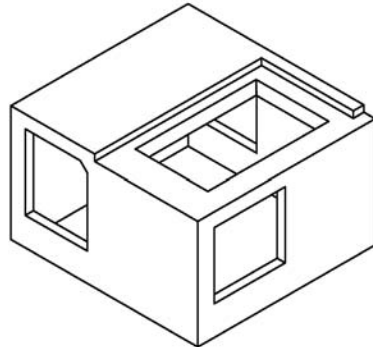

Cable Trough Pit

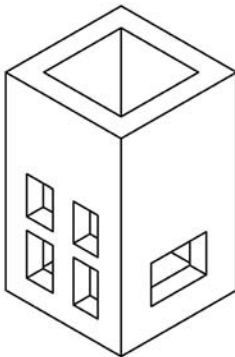

Special shaped openings

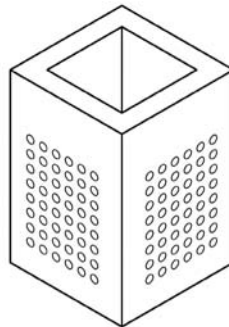

Seepage Pits

Step irons supplied loose or installed on request.

### Precast Solutions

Beresford Concrete Products Pty Limited ABN 66 002 104 323 trading as

**BCP Precast PO Box 4197 Lake Haven NSW 2263**

Phone: 1800 804 134 Fax: 1800 199 916 Email: [sales@bcp.com.au](mailto:sales@bcp.com.au) Web: [www.bcp.com.au](http://www.bcp.com.au)

## TYPICAL CUSTOM PRECAST PITS

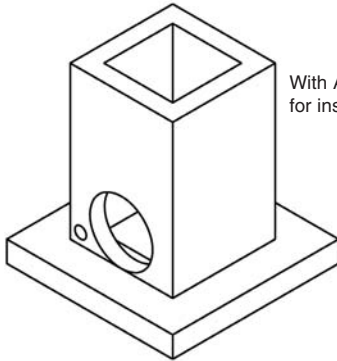

With Anti Flotation nib suitable for installation in soft ground

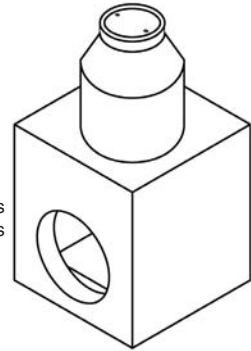

With Manhole Risers for very deep pits

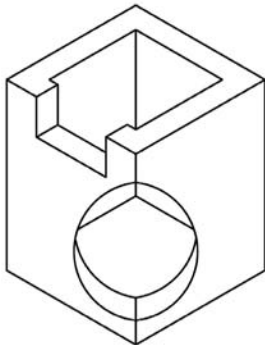

Letterbox openings, pipe penetrations in corners to suit customers' requirements

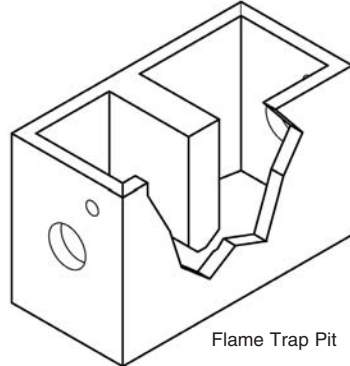

Flame Trap Pit

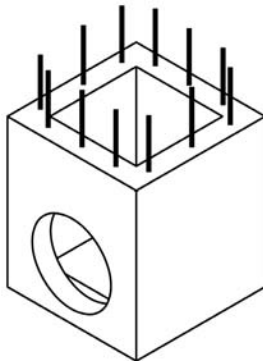

Flat top with protruding reinforcement for insitu completion

Rectangular penetrations

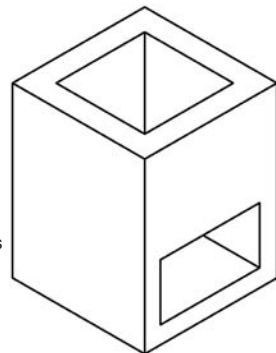

Step irons supplied loose or installed on request.

### Precast Solutions

Beresford Concrete Products Pty Limited ABN 66 002 104 323 trading as

**BCP Precast PO Box 4197 Lake Haven NSW 2263**

Phone: 1800 804 134 Fax: 1800 199 916 Email: [sales@bcp.com.au](mailto:sales@bcp.com.au) Web: [www.bcp.com.au](http://www.bcp.com.au)