

WHEEL STOPS

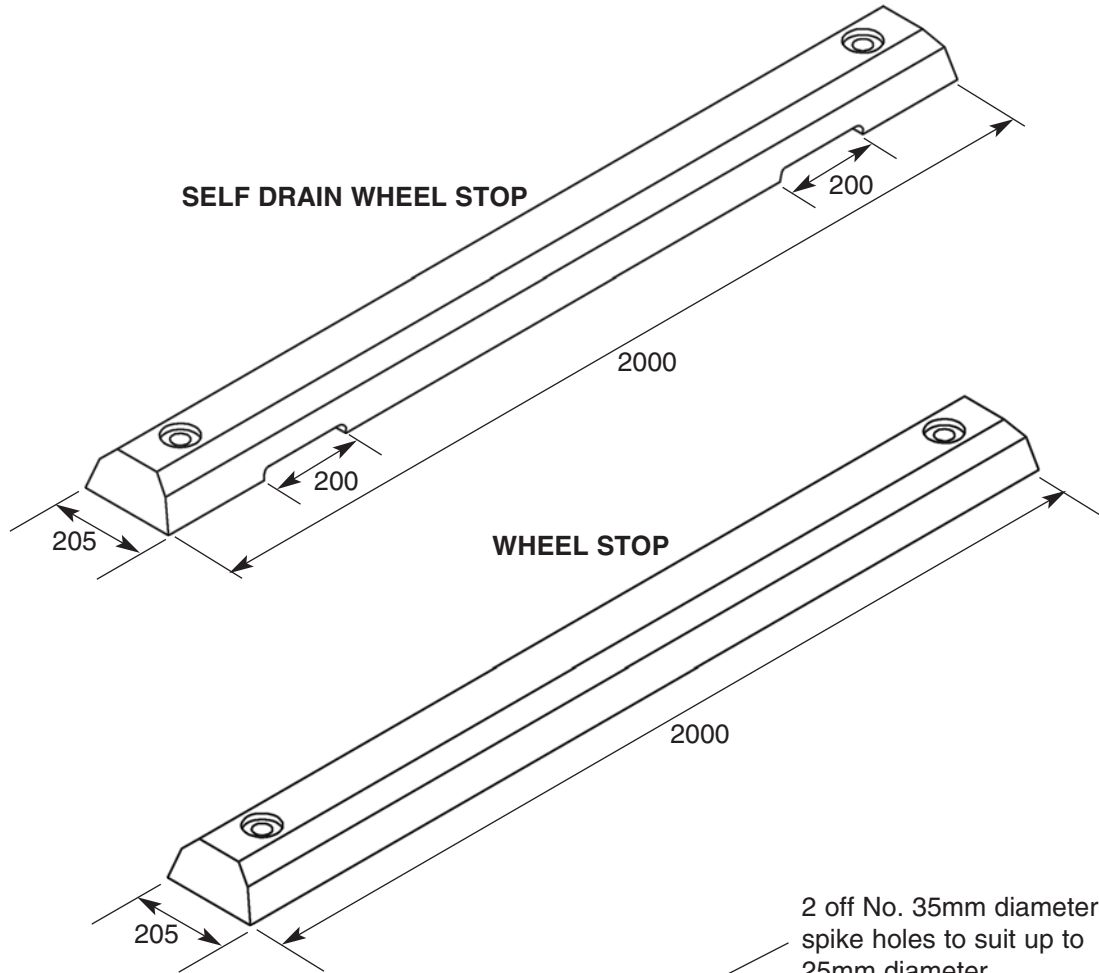

2 off No. 35mm diameter spike holes to suit up to 25mm diameter.

300mm minimum length



100mm Wheel stop
125mm Self drain wheel stop

TYPICAL SECTION

Order Code	Description	Mass Kg
XWS-02001	Wheel Stop - 2000mm long	90
XWS-02000	Self Drain Wheel Stop - 2000mm long	90

RTA ELSHOLZ REDIRECTIVE KERB

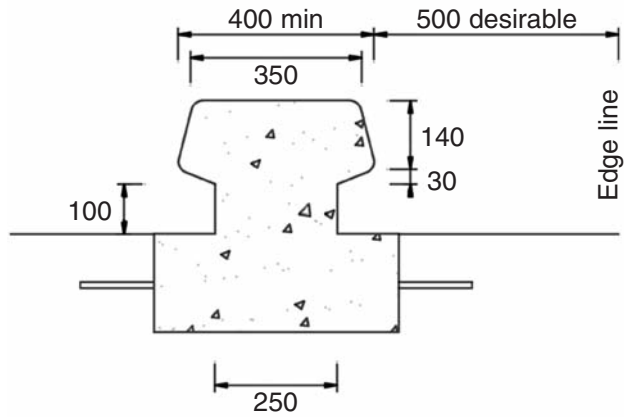
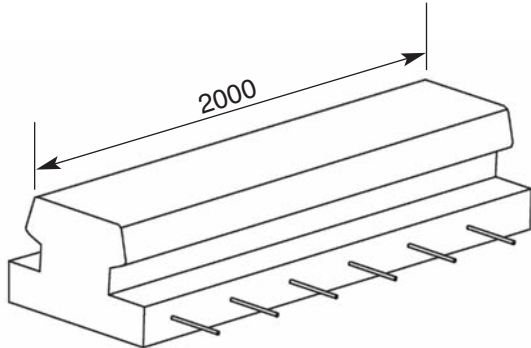

ELSHOLZ - Narrow median
(Concrete pavement and bridge decks)

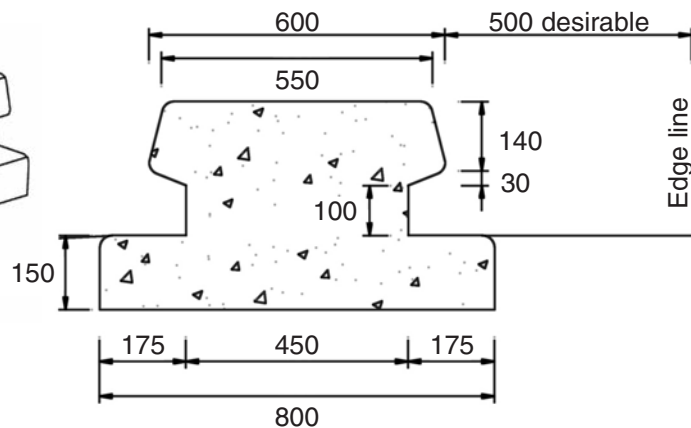
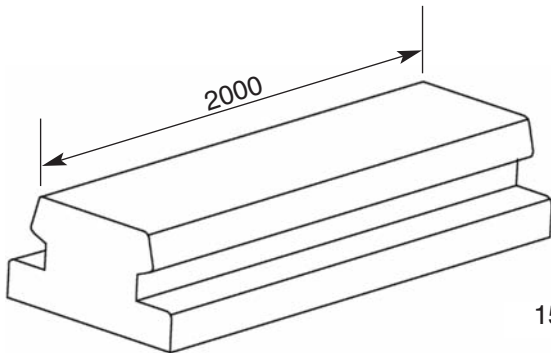

ELSHOLZ - Typical median installation
(Flexible pavement)

NOTE

- Vertical dimensions as shown are critical for this barrier's performance. No pavement layer buildup directly against the kerb.
- This is a Redirection Kerb suitable for speed zones of 70km/h or less.
- RTA 'Elsholz' concrete kerb median & nearside installation, refer to RTA drawing MD.R132.D03.A.
- Transition kerbs available on request.

Order Code	Description	Mass kg
ELSKER-01	Typical median installation (flexible pavement)	870
ELSKER-02	Narrow median (conc. pavement & bridge decks)	1270

RETAINING WALLS

BUILT TO CUSTOMERS' SPECIFICATIONS

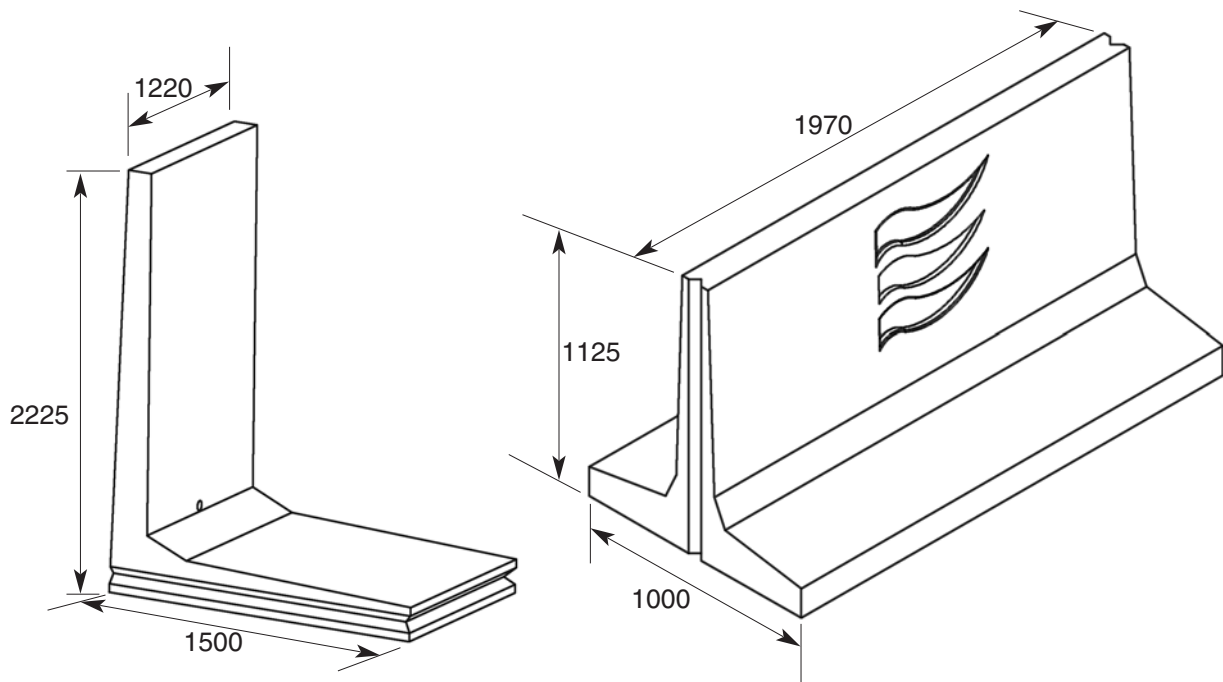

TYPE F BARRIER (JERSEY KERB)

- Available for permanent and temporary barriers
- Manufactured to RTA specification
- Drainage runners available upon request
- Available in 3 and 6 metre lengths
- Terminating ends available

Order Code	Description	Mass kg
JK-003-B	3 Metre barrier	2060
JK-006-B	6 Metre barrier	4100
JK-006-BEND	6 Metre terminating end	4000

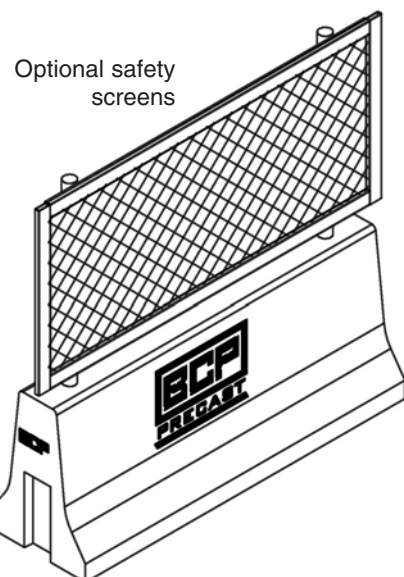
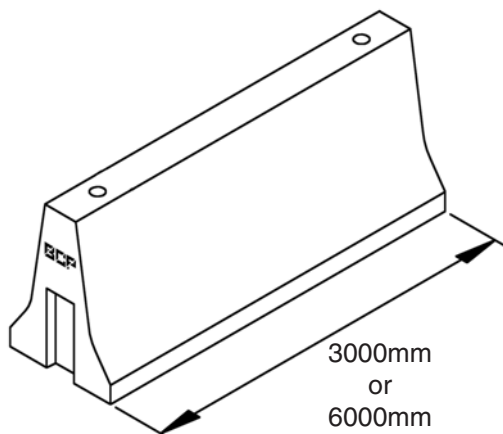

BALLAST CAGE (LOBSTER POT) PITS for RAILCORP



Ballast cage seated
over outside edge of
pit or riser.

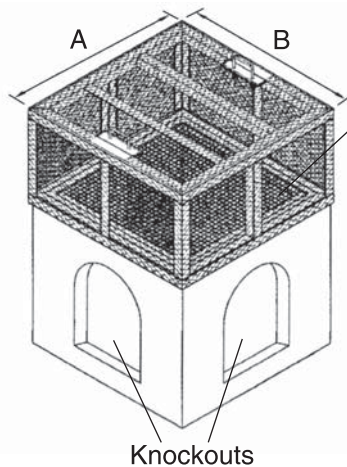

Heavy duty GMS
grate sitting in pit or
riser top rebate.

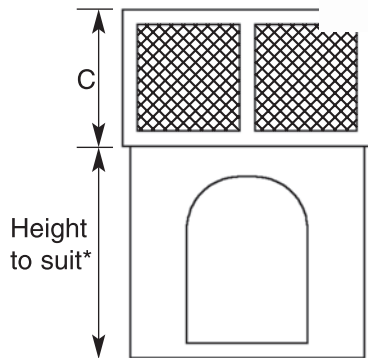

- Ballast cages supplied by themselves or as a complete system, which includes pit, grate and cage.

* For pit dimensions refer to BCP Standard Pits & Riser System

Order Code	Description	Dimensions				Mass Kg**
		A	B	C	D	
Lobpot-4545AS	Suit 450 x 450 pits	640	640	600	Refer to Standard Pits & Risers	66
Lobpot-6060AS	Suit 600 x 600 pits	818	818	600		80
Lobpot-6090AS	Suit 600 x 900 pits	1118	818	600		91
Lobpot-9090AS	Suit 900 x 900 pits	1120	1120	600		103

** Cage only

RETAINING WALL PANELS for RAILCORP

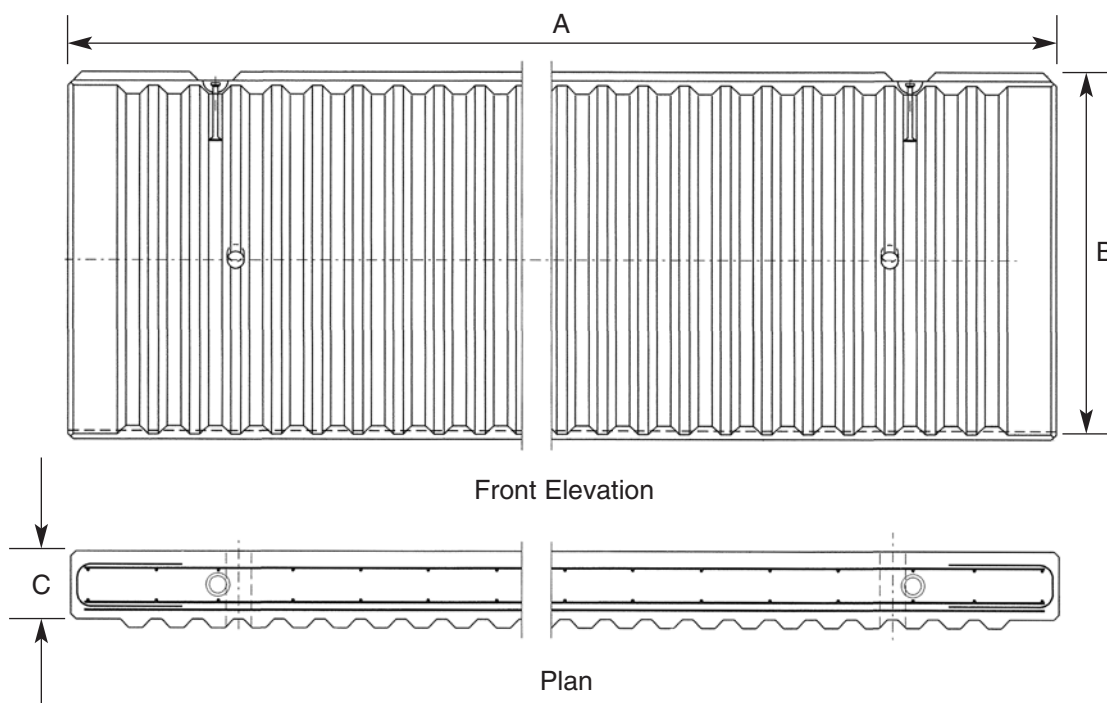

- Lengths, heights & thicknesses may be varied to suit specific site requirements.
- Reinforcement shall be in accordance with AS/NZ 4671 and in accordance with site design.
- Concrete shall be 40MPa at 28 days or specifically as requested.

Order Code	Description	Dimensions			Mass kg
		A	B	C	
RWP-0500	Retaining wall panel 2900 x 500	2900	500	195	800
RWP-1000	Retaining wall panel 2900 x 1000	2900	1000	195	1000
RWP-1500	Retaining wall panel 2900 x 1500	2900	1500	195	1500
RWP-2000	Retaining wall panel 2900 x 2000	2900	2000	195	2000
RWP-2500	Retaining wall panel 2900 x 2500	2900	2500	195	2500
RWP-3000	Retaining wall panel 2900 x 3000	2900	3000	195	3000

Beresford Concrete Products Pty Limited ABN 66 002 104 323 trading as

BCP Precast PO Box 537 Moorebank NSW 1875

Phone: 1800 804 134

Fax: 1800 199 916

Email: sales@bcp.com.au

Web: www.bcp.com.au

