

KERB ENTRY UNITS

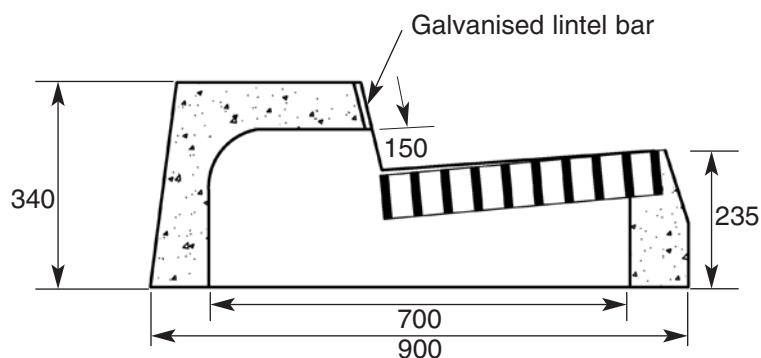

Designed to suit precast pits -
900 x 600
900 x 750
900 x 900

Grate may be located left (L),
centre (C) or right (R).
(1200mm opening centre only).

Higher loading grate available
on request

All units fitted with BCP Lift foot
anchors for safe handling.

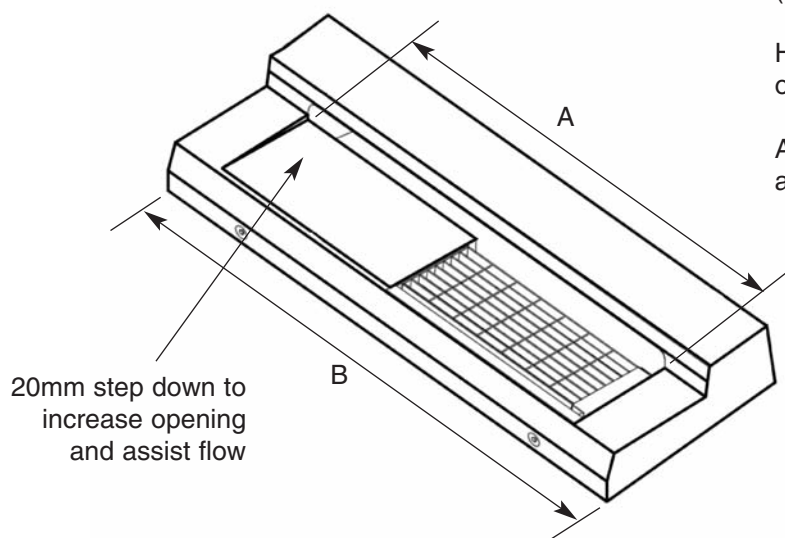

20mm step down to
increase opening
and assist flow

Order Code	Opening A mm	Overall Length B mm	Mass kg
KEU-01200	1020	1500	800
KEL-01800	1850	2400	1000
KER-01800			
KEC-01800			
KEL-02400	2370	3000	1200
KER-02400			
KEC-02400			
KEL-03000	3090	3600	1400
KER-03000			
KEC-03000			

KERB LINTELS

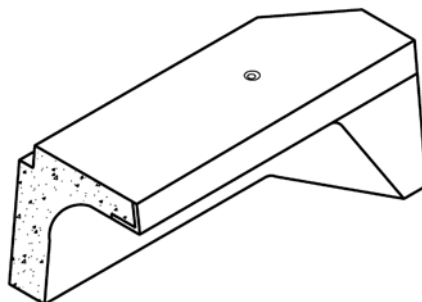
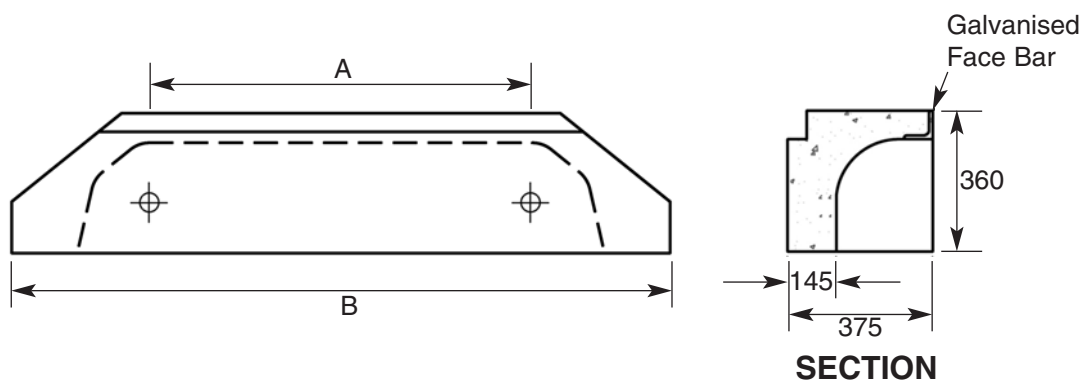

Order Code	Opening A mm	Overall Length B mm	Mass kg
KIL-01200	1300	1800	430
KIL-01800	1740	2400	580
KIL-02400	2500	3000	680
KIL-03000	3000	3600	780
KIL-03600	3600	4200	880

RTA KERB LINTELS TYPE SA

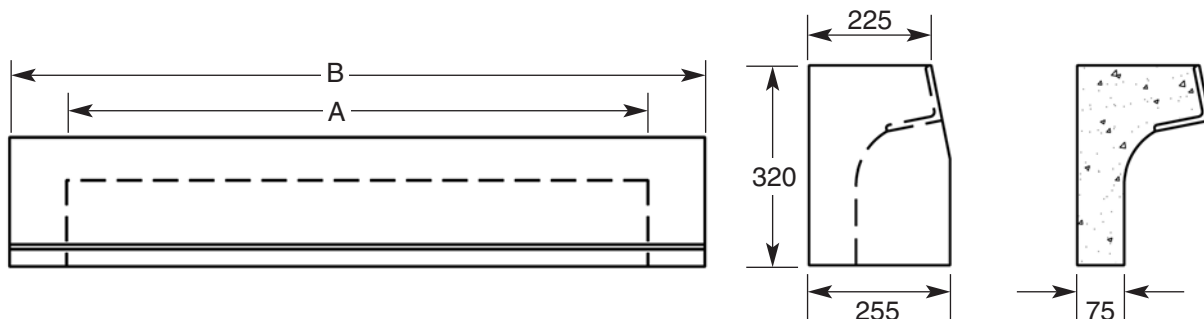

Order Code	RTA Dwg. No.	Opening A mm	Overall Length B mm	Mass kg
RTA-SA1	MD.R11.B03.A	1020	1220	160
RTA-SA2	MD.R11.B03.A	2050	2250	280
RTA-SA3	MD.R11.B03.A	3080	3280	390

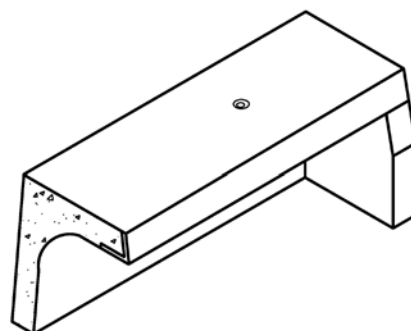

RTA KERB LINTELS TYPE SF

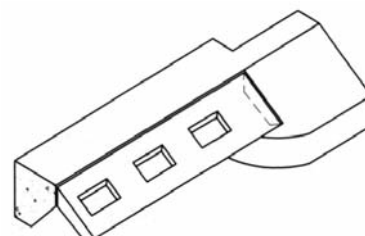
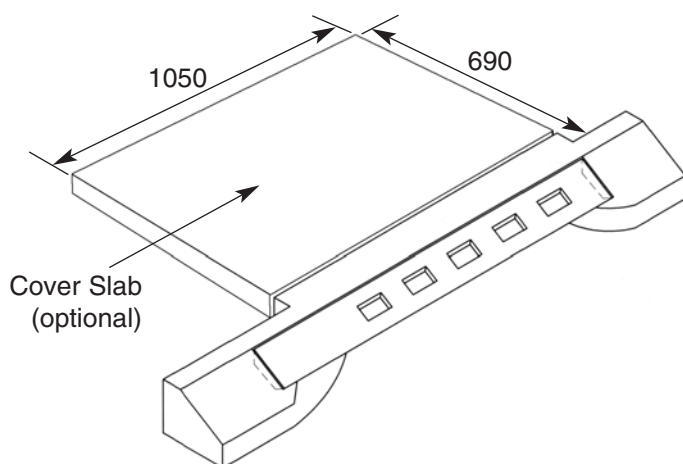

Order Code	RTA Dwg. No.	Opening A mm	Overall Length B mm	Mass kg
KIL-SFL	MB.R11.B09.A.1	1250	1750	140
KIL-SFR	MB.R11.B09.A.1	1250	1750	140

Order Code	Description	Mass kg
KIL-SF-COV	Cover Slab	150

RTA HIGHWAY KERB ENTRIES

TYPE SA - EXTRA HEAVY DUTY

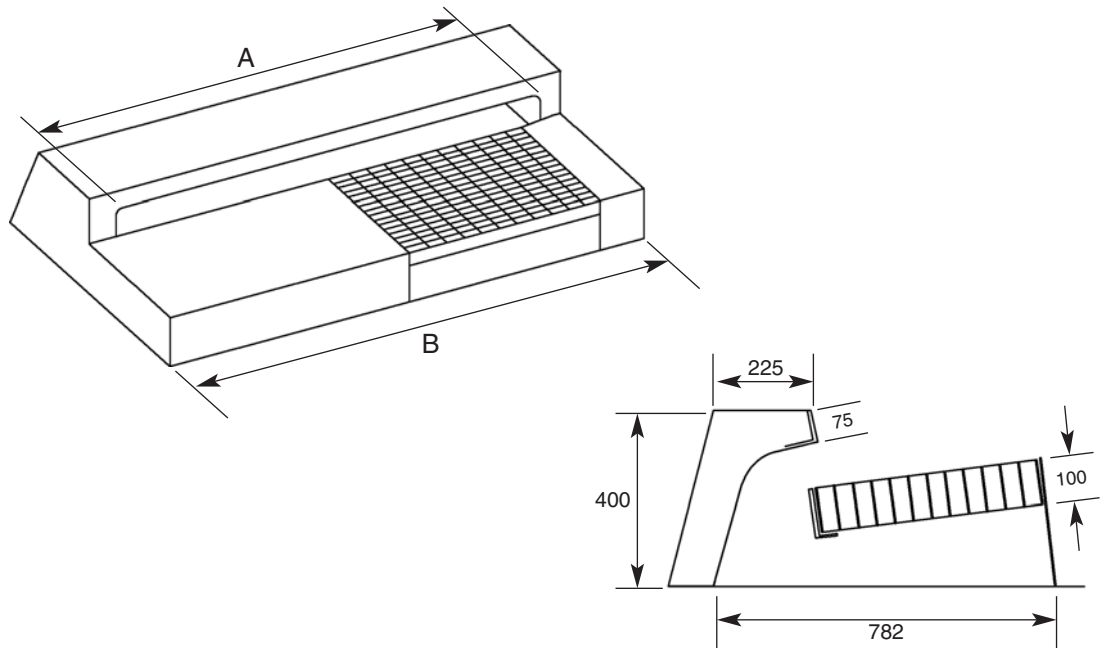

Order Code	Opening A mm	Overall Length B mm	Mass kg
KEU-SA1	940	1130	800
KEL-SA2	2010	2240	1000
KER-SA2	2010	2240	1000

- Grates may be located left or right on SA2 kerb entries. Centre only on SA1
- All units are fitted with BCP lift foot anchors for safe handling.